

INTEGRATED SERVICES DIGITAL NETWORK (ISDN)

EEEN 464 – DIITAL COMMUNICATION

Friday, 21 March 2025

WHERE WE ARE IN THE SYLLABUS

Course Purpose:

To enable students understand the fundamental principles of digital transmission systems as used in fixed and mobile telephony, wired and wireless computer networks, data storage and digital broadcasting.

Expected Learning Outcomes:

At the end of the course, students will be able to:

- (i) describe binary and duo binary pulse Amplitude Modulation (PAM);
- (ii) design digital coding schemes;
- (iii) derive error performance equations for digital modulation schemes(ASK,FSK,PSK,DPSK);
- (iv) state strengths and weaknesses of M-ary PSK with QAM signaling schemes;
- (v) design a basic digital communication systems.

Course Content:

Signal digitization: Pulse Amplitude Modulation (PAM), sampling theorems and sampling circuits, Pulse code modulation (PCM). Quantization and signal conditioning: Uniform and non-uniform quantization; companding methods; vocoders; signal-to- quantization noise ratio. Waveform coding: Pulse transmission, PCM, Pulse-shaping; Delta modulation; adaptive delta modulation; Differential Pulse Code Modulation (DPCM), M-ary encoding. Digital Modulation: Amplitude shift keying (ASK), Frequency Shift Keying (FSK), Phase Shift Keying (PSK), Quadrature Amplitude Modulation (QAM) and Differential Phase Shift Keying (DPSK). Signal recovery in ASK, FSK and PSK; Gaussian Minimum Shift Keying (GMSK); Performance comparison. Information theory: information sources, entropy, channel capacity; Source Coding; entropy coding. Error control: Error control coding techniques; Transmission errors; Error detection methods; intersymbol interference and the eye pattern; Linear block codes; Cyclic codes; convolution codes. Multiplexing: Frequency division multiplex (FDM), Time Division Multiplexing (TDM), plesiochronous digital hierarchy (PDH). Spread spectrum communication: Direct sequence and frequency hopping methods; synchronization, spreading codes and their generation. Data transmission: Local data transmission protocols (Ethernet, token ring); Modems; high Asymmetric Digital subscriber line (ADSL); Very-high Speed Digital subscriber line (VDSL), integrated services digital network (ISDN).

WHAT IS ISDN?

1. **Integrated Services Digital Network (ISDN)** is a set of communication standards for simultaneous digital transmission of voice, video, data, and other network services over the traditional circuits of the public switched telephone network.
2. **ISDN is a circuit-switched telephone network system**, which also provides access to packet switched networks, designed to allow digital transmission of voice and data over ordinary telephone copper wires, resulting in potentially better voice quality than an analogue phone.
3. **ISDN was first defined in 1988.**
4. **Prior to 1988, the telephone system was viewed as a way to transport voice**, with some special services available for data using modems.

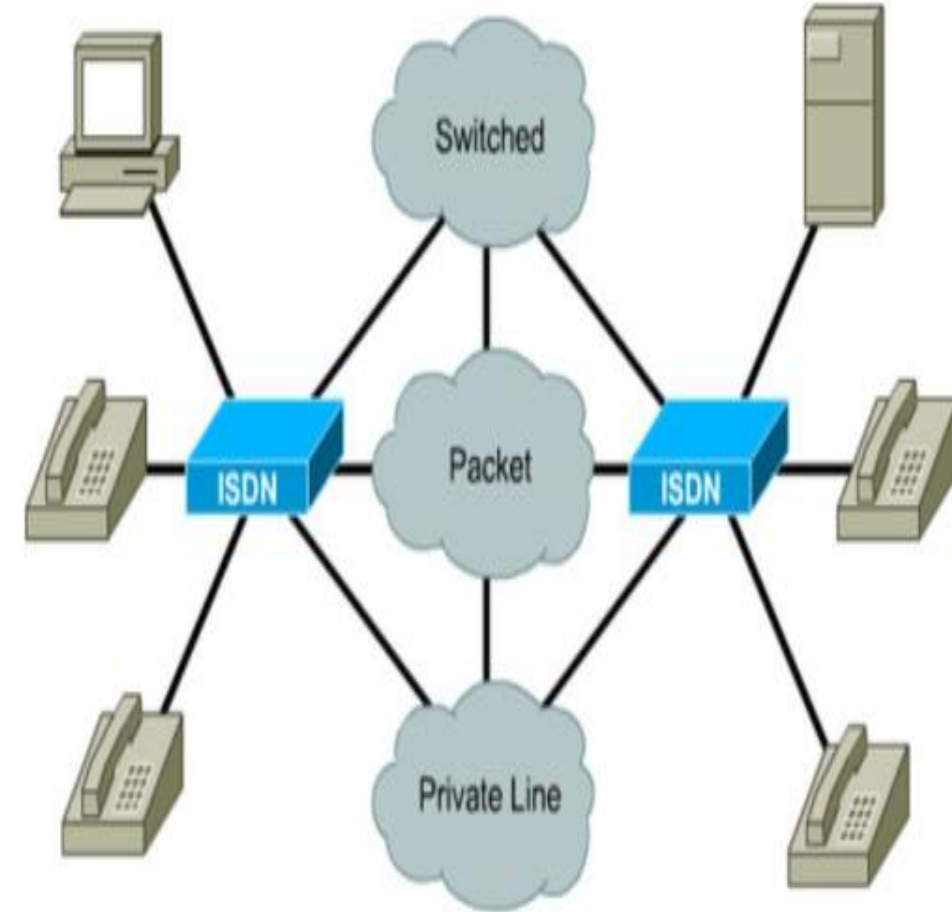

ELEMENTS OF INTEGRATED SERVICES DIGITAL NETWORK

1. ISDN provides several communication channels to customers via local loop lines through a standardized digital transmission protocol.
2. ISDN standard defines a vendor independent digital interface between user terminals (telephone, fax and computer) and the telecommunication network.
3. ISDN compliments the traditional wired telephone by enabling a telephone pair to carry voice and data simultaneously.

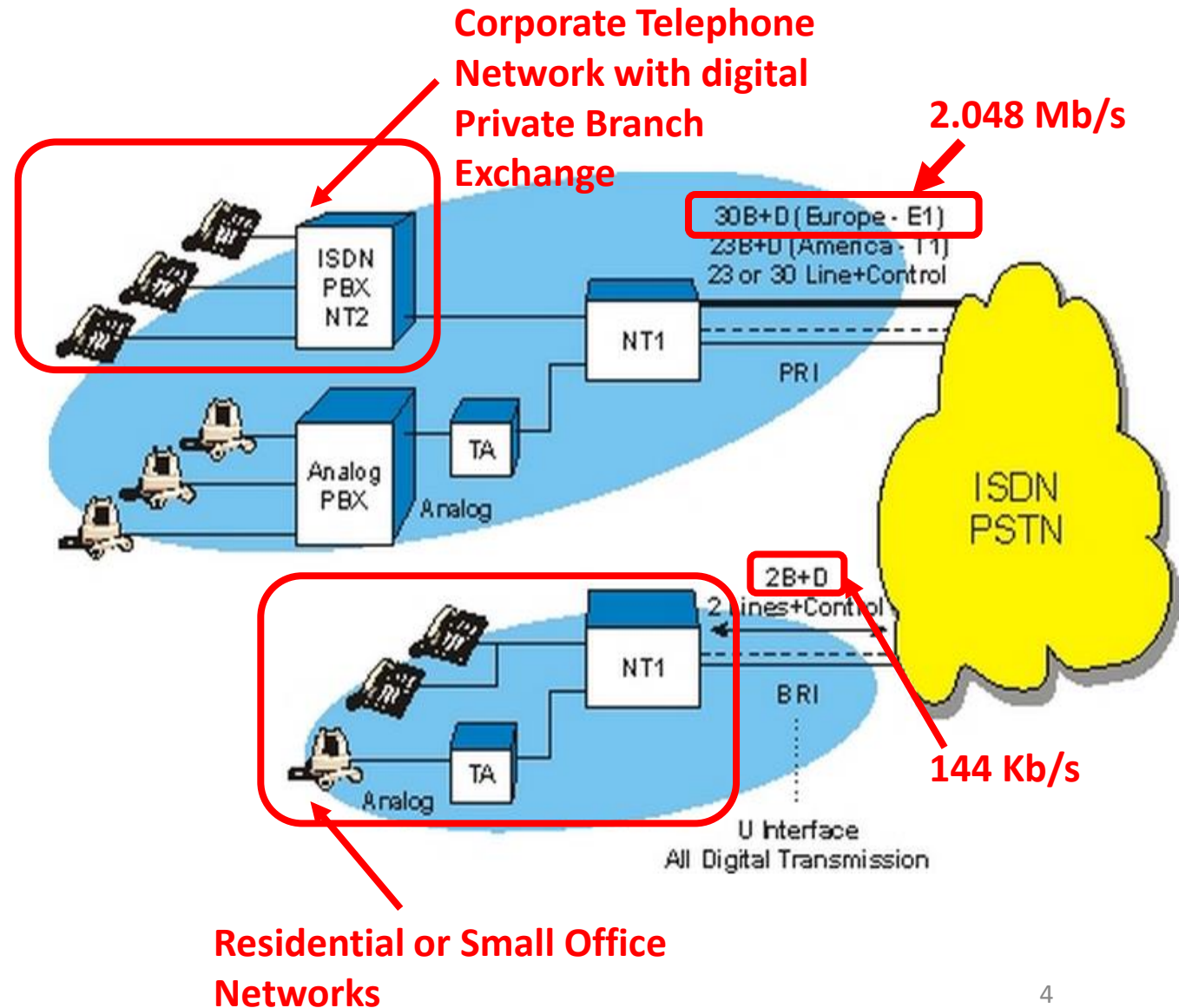

ISDN DATA RATES

1. **Basic Rate Interface (BRI)** operates at **144 Kb/s** and can carry two telephones (128 kb/s) together with signaling/synchronization (16kb/s). It is used to serve homes and small offices.
2. **Primary Rate Interface (PRI)** operates at **2.048 Mb/s**. It is used to provide services to corporate offices or to serve a group of users in a rural area.
3. PRI can carry 30 voice channels, One synchronization channel and 1 signaling channel.

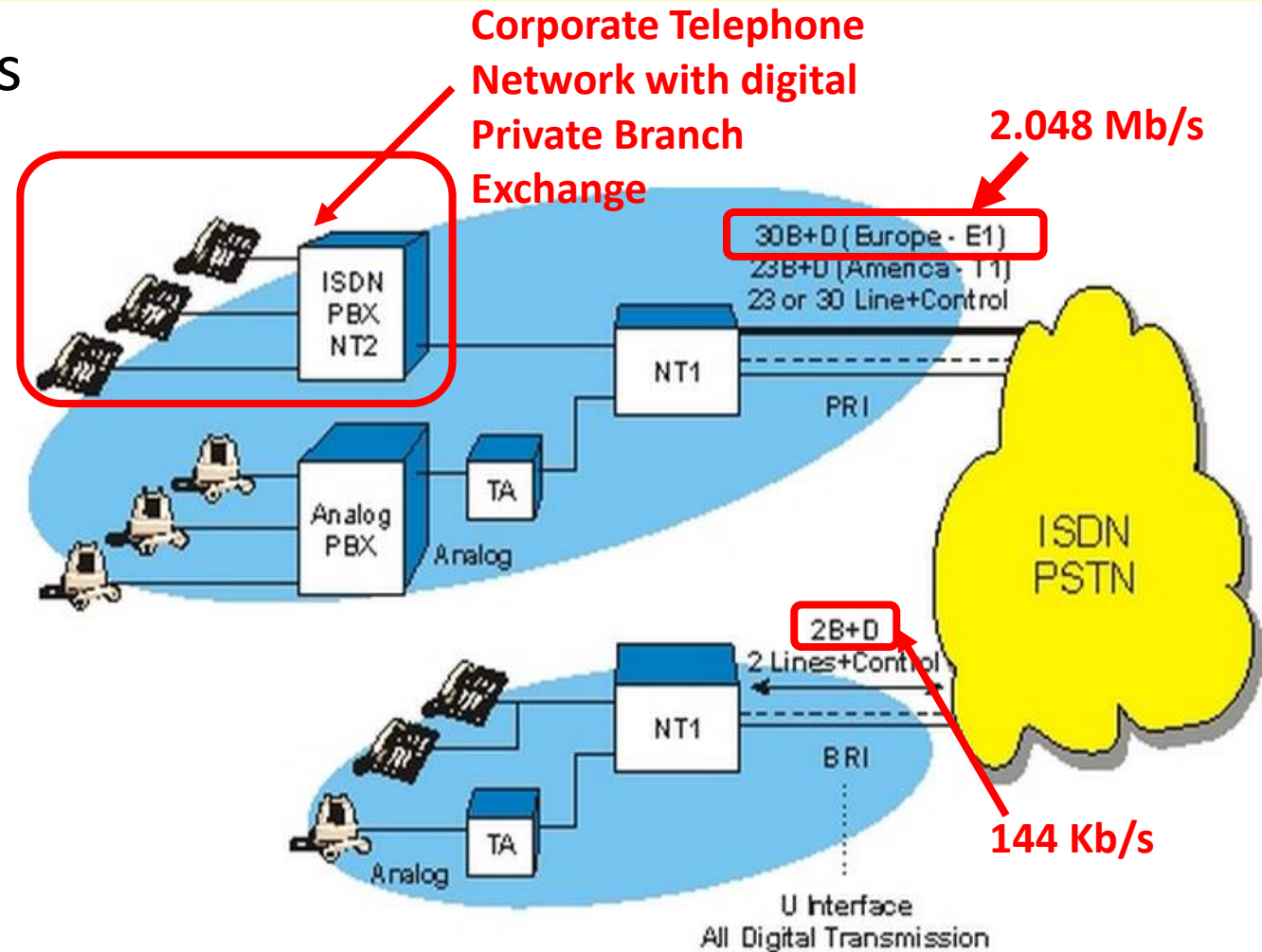

**Corporate Telephone Network
with digital Private Branch
Exchange**

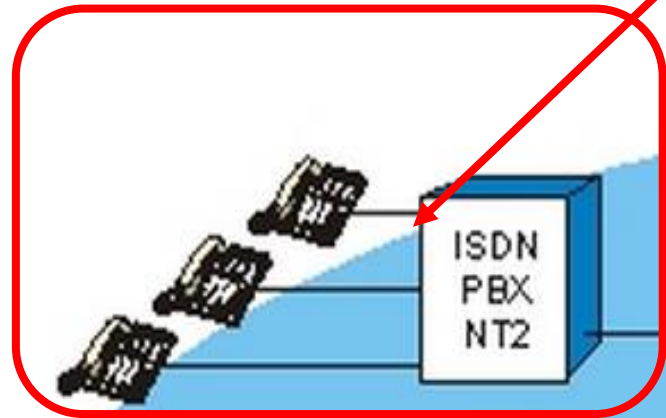

30B+D (Europe - E1)
23B+D (America - T1)
23 or 30 Line+Control

2.048 Mb/s

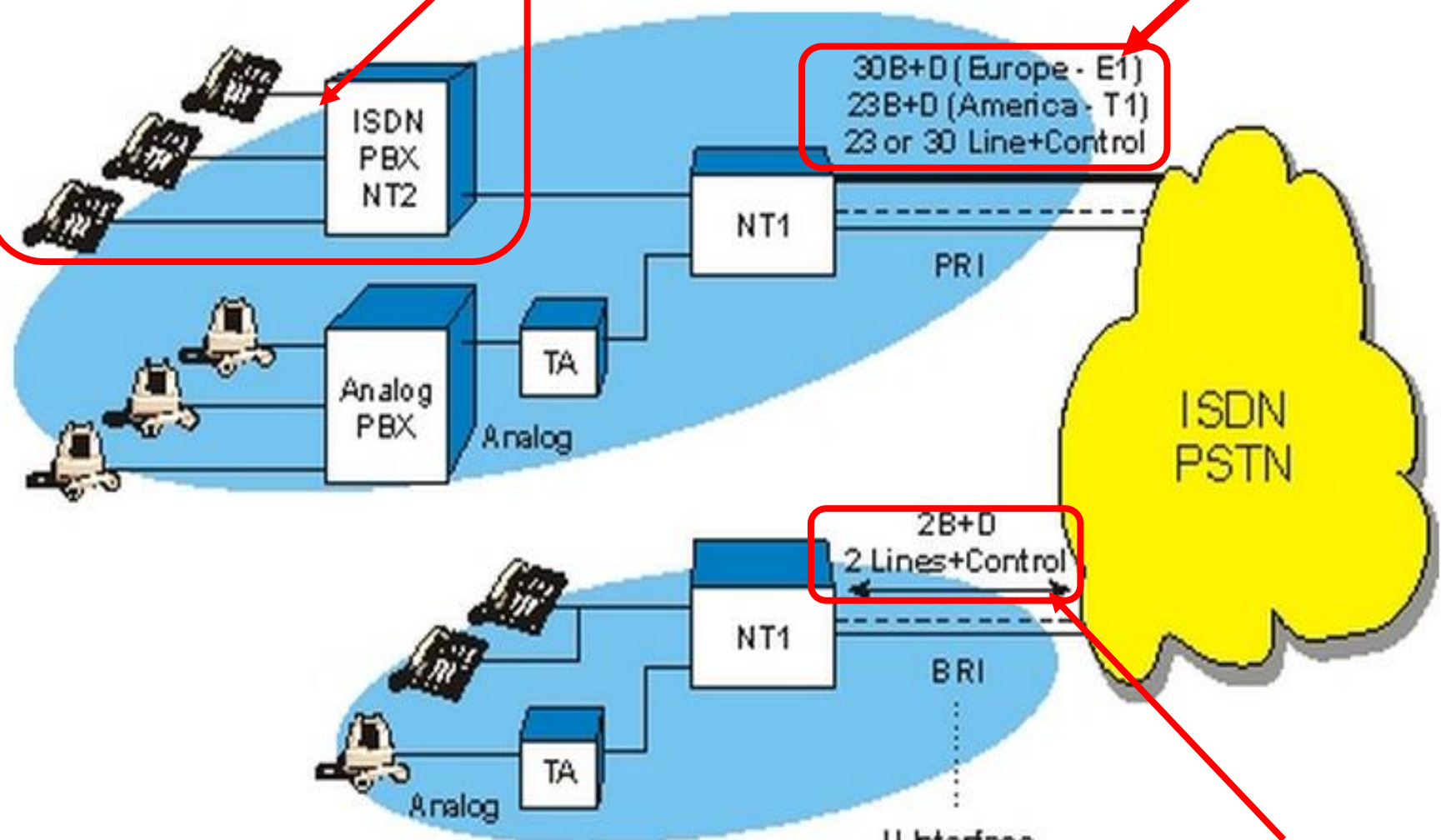

2B+D
2 Lines+Control

144 Kb/s

U Interface
All Digital Transmission

MULTIPLEXING PCM SIGNALS – E1 (RECAP)

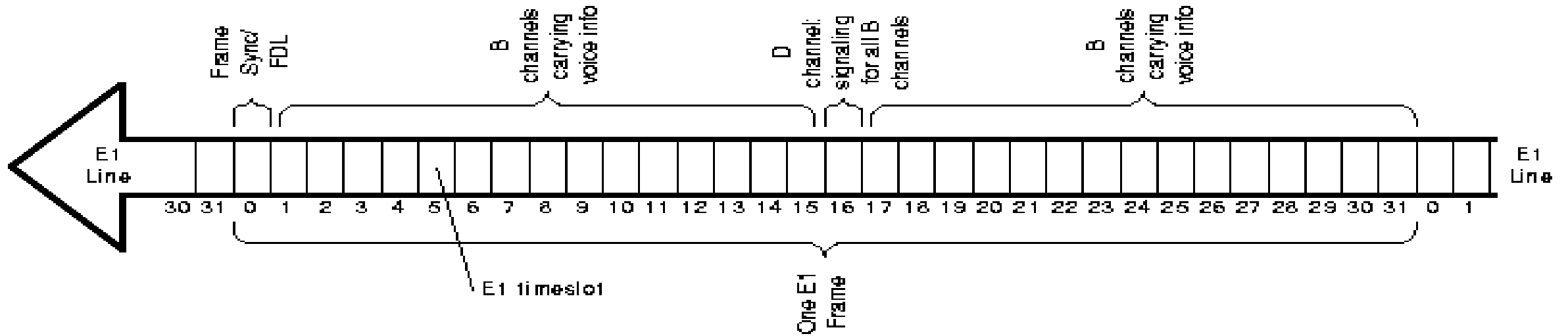

1. **Timeslot 1** is used to carry synchronization.
2. **Timeslot 16** is used to carry signaling data.



Animation of the TDM of PCM channels. 32 timeslots are combined to create a 2.048 Mb/s composite signal

ISDN SERVICES

There are two kinds of services provided by ISDN.

1. Network services

Network services carry the interactions between the user and the network (**synchronization and signalling**), **For example: setting up calls and disconnecting them.**

2. Bearer services

Bearer services carry data between two users. For example: **voice, data or fax information encoded as a bit stream.**

NETWORK/SIGNALLING SERVICES

1. Network or Signalling Services define how the user and the network interact with each other in order to manage calls.
2. The user can use Network Services to request the network to perform functions such as making and clearing calls, transferring calls to another user, etc.

BEARER SERVICES

1. Bearer services include voice calls, fax and modem calls, and connections to the Internet.
2. There are two forms of bearer service:

(a) Structured Data

the information passing over the bearer service **is in a format that is understood by the telecommunication network**. Voice is an example of structured data. Because the network knows that the connection carrying voice, it can convert the data into an analogue signal in the event that the call is connected to an ordinary analogue phone.

(b) Unstructured Data

The format of the information is not understood by the network, but is understood by the two users at either end of the service.

BENEFITS OF ISDN

Benefits of ISDN included:

1. Carried a variety of user traffic signals, including data, voice, and video
2. Offered much faster call setup than modem connections
3. Provides a faster data transfer rate than modems
4. Suitable for negotiated Point-to-Point Protocol (PPP) links

Further Reading:

[Integrated Services Digital Network \(ISDN\) – GeeksforGeeks](#)

<https://rydalgroup.co.uk/what-is-isdn-advantages-types-and-who-uses-it/>

FACTORS LEADING TO THE DEATH OF ISDN

1. The number of ISDN channels used by businesses has shrunk considerably globally.
2. The causes are as follows:
 - a) **The greater proliferation of mobile phones** has meant that fewer people are reliant on legacy phone systems.
 - b) **The greater availability of highspeed internet** through alternative media such as fibre optic cables and satellite.
 - c) **New internet-based telephony systems (read IP Telephones) now come with more advanced features.**

IS TELKOM KENYA STILL OFFERING ISDN? YES

QUALITY VOICE SERVICE WITH 24 HOURS SUPPORT - ISDN

Integrated Services Digital Network (ISDN) is a transmission service that offers you voice services at your premises and allows for numerous simultaneous calls at any given time.

ISDN 1

15C

***15,000 Monthly Bundle** – (Ksh 15,000 deposit)

Ksh 2/= Calling within Telkom network (Telkom Mobile & Fixed)

Ksh 3/= Calling outside Telkom network

Up to **6,000 mins** available in bundle

ISDN 2

30C

***30,000 Monthly Bundle** – (Ksh 30,000 deposit)

Ksh 2/= Calling within Telkom network (Telkom Mobile & Fixed)

Ksh 3/= Calling outside Telkom network

Up to **12,000 mins** available in bundle

ISDN 3

45C

***45,000 Monthly Bundle** – (Ksh 45,000 deposit)

Ksh 2/= Calling within Telkom network (Telkom Mobile & Fixed)

Ksh 3/= Calling outside Telkom network

Up to **18,000 mins** available in bundle

Further reading:

<https://telkom.co.ke/business/sme/fixed-voice/isdn/>